

American Standard Spindle Nose Data

Source: American Standard Bulletin ASA B5.9 1960

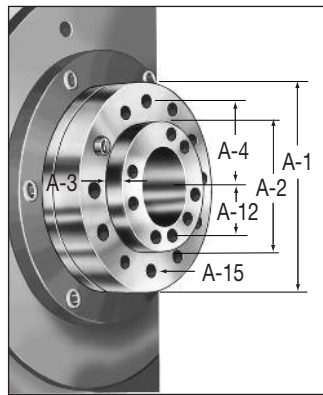
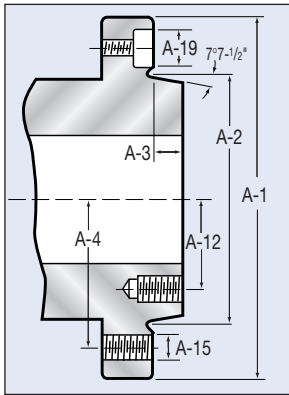

Type A American Standard A-1, A-2, B-1, B-2 Spindle

	A5	A6	A8	A11	A15	A20
A-1	5 1/4	6 1/2	8 1/4	11	15	20 1/2
A-2*	3.2505	4.1880	5.50075	7.75075	11.251**	16.251**
A-3***	.5625	.625	.6875	.750	.8125	.875
A-4	2 1/16	2 5/8	3 3/8	4 5/8	6 1/2	9 1/8
A-12	17/32	1 5/8	2 3/16	3 1/4	4 7/8	7 1/4
A-15	7/16-14	1/2-13	5/8-11	3/4-10	7/8-9	1-8

*Tolerance +.0005/-0.000 **Tolerance +.001/-0.000 ***Tolerance +.000/-0.001

A-1 Has tapped holes on both the inner bolt circle and outer bolt circle.

A-2 Has tapped holes on the outer bolt circle, but has no hole on inner bolt circle.

B-1 Has drilled holes on the outer bolt circles, and has tapped holes on inner bolt circle.

B-2 Has drilled holes on the outer bolt circles, but has no holes on inner bolt circle.

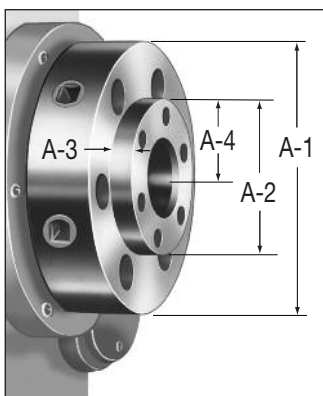
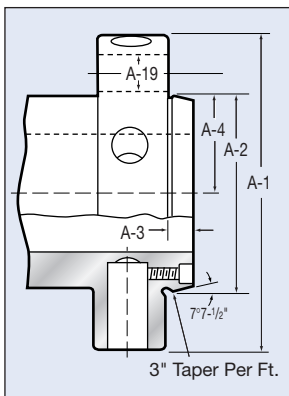

Type D1 American Standard cam lock spindles

	D3	D4	D5	D6	D8	D11
A-1	3 5/8	4 5/8	5 3/4	7 1/4	8 7/8	11 3/4
A-2*	2.1250**	2.5005	3.2505	4.1880	5.50075	7.75075
A-3	7/16	7/16	1/2	9/16	5/8	11/16
A-4	1 25/64	1 5/8	2 1/16	2 5/8	3 3/8	4 5/8
A-19	.594	.656	.781	.906	1.031	1.218

*Tolerance +.0005/-0.000 **Tolerance +.00025/-0.000

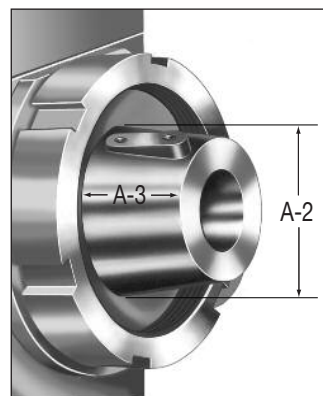
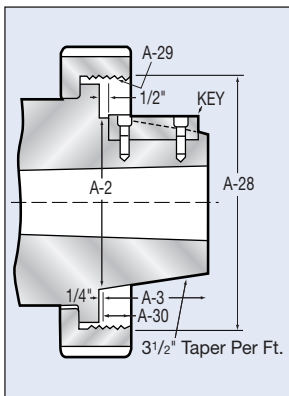

Type L long taper key drive

	L00	L0	L1	L2	L3
A-2*	2 3/4	3 1/4	4 1/8	5 1/4	6 1/2
A-3	2	2 3/8	2 7/8	3 3/8	3 7/8
A-28	3 3/4	4 1/2	6	7 3/4	10 3/8
A-29	6TPI	6TPI	6TPI	5TPI	4TPI

*Tolerance +.002/-0.000

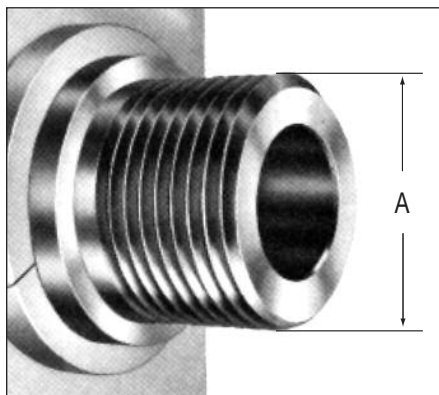
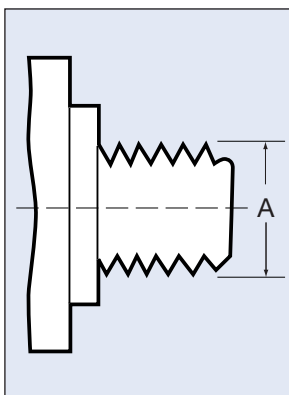

Threaded Spindle

Thread size
A
1 1/2-8
2 1/4-8
2 3/8-6